

---

# Pure-Flo<sup>®</sup>

## Handwheel Operated Valves (903, 913, 963)

### Instruction Manual

This manual provides installation, operation and maintenance instructions for Pure-Flo<sup>®</sup> Diaphragm Valves (with 903, 913, 963 Handwheel Bonnets). If additional information is required, please contact:

ITT Industrial Process  
33 Centerville Road, P.O. Box 6164  
Lancaster, PA 17603-2064 USA  
Or call: (800) 366-1111  
(717) 509-2200  
Fax: (717) 509-2336  
Website: [www.ittpureflo.com](http://www.ittpureflo.com)  
E-mail: [pureflo.custserv@itt.com](mailto:pureflo.custserv@itt.com)

---

#### CONTENTS:

- 0.0 General
- 1.0 Installation
- 2.0 Operation & Adjustment
- 3.0 Maintenance

#### **WARNING**

Valves and related products are designed and manufactured using good workmanship and materials, and they meet all applicable industry standards. These valves are manufactured with various materials, and they should be used only in services recommended by a company engineer.

Misapplication of the product may result in injuries or property damage. A selection of valve and valve components of the proper material and consistent with the particular performance requirement is important for proper application.

Examples of misapplication or misuse of any products include use in an application in which the pressure/temperature rating is exceeded or failure to maintain valve or related product as recommended and use of products to handle caustic and/or hazardous substances when not designed for that purpose.

If valve exhibits any indication of leakage, do not operate. Isolate valve and either repair or replace.

**Holland<sup>®</sup>**  
**APPLIED TECHNOLOGIES**  
Indianapolis • Chicago • San Juan  
[www.hollandapt.com](http://www.hollandapt.com)  
800-800-8464

## 0.0 GENERAL

This manual provides installation and maintenance instructions for manually operated Pure-Flo diaphragm valves. If additional information is required, or if your valves have pneumatic, electric, or any type of power actuation, contact:

ITT Pure-Flo  
33 Centerville Rd.  
Lancaster, PA 17603  
(717) 509-2200  
Attention: Sales Department

### 0.1 Safety



The safety precautions in these operating instructions are specially marked with the standard symbol for danger when non-observance could result in personal injury, loss of life or property damage.

#### CAUTION!

Non-observance of these safety precautions can endanger the valve and its functions.

#### 0.1.1 Qualifications and training of personnel

The personnel responsible for operation, maintenance, inspection and assembly must be appropriately qualified.

The operating company must precisely define the responsibilities, competence and supervision of the personnel. If the personnel lack the necessary knowledge, they are to be trained and instructed. If required this can be carried out by the manufacturer/supplier of the valve by order of the operating company. Furthermore, the operating company is to ensure that the contents of the operating instructions have been fully understood by the personnel.

#### 0.1.2 Dangers through non-observance of the safety precautions

The non-observance of the safety precautions can result in the endangering of lives as well as the environment and the valve. The non-observance of the safety precautions can lead to the loss of all claims for damages.

Non-observance can result in the following:

- Failure of important functions of the valve/plant.
- Endangering of lives by electrical, mechanical and chemical influences.
- Endangering the environment through leakage of dangerous materials.
- Personal injury or property damage.

#### 0.1.3 Safety awareness at work

Attention must be paid to the safety precautions in these operating instructions, the current national regulations concerning the prevention of accidents as well as any labor, company and safety-regulations of the operating company.

### 0.1.4 Safety precautions for the operating company/individual operator

- If hot or cold components of the valves are a source of danger, these components must be secured against contact by operating company.
- Contact guard for moving parts may not be removed when valve is in operation.
- Do not hang items off the valves. Any accessories must be firmly or permanently attached.
- Do not use the product as a step or hand hold.
- Do not paint over identification tag, warnings, notices or other identification marks associated with the product.

### 0.1.5 Safety precautions for maintenance, inspection and assembly

Work on externally actuated valves should only be carried out when the valve is removed from service. Valves that have been exposed to harmful media such as caustic chemicals must be decontaminated.

On completion of work, all safety and protective equipment must immediately be fitted again or reactivated.

Before the re-operation, attention should be paid to the points in the following sections.

### 0.1.6 Unauthorized reconstruction, manufacture and use of spare parts

Reconstruction or modification of the valve is only admissible after consultation with the manufacturer.



Genuine spare parts and accessories authorized by the manufacturer serve to maintain safety. The use of other parts can annul all liability for the consequences.

Manufacturer's parts are not to be used in conjunction with products not supplied by the manufacturer. The use of manufacturer's parts with products not supplied by the manufacturer can annul all liability for the consequences.

### 0.1.7 Inadmissible modes of operation

The operational reliability of the valve supplied is only guaranteed when used as designated. The operating limits given on the identification tag and in the data sheet may not be exceeded under any circumstances.

If the product label is missing or worn contact manufacturer at the address listed within this manual for specific instructions.

## 0.2 Transport and storage



The universally recognized technical standards and the regulations regarding prevention of accidents must be observed at all times when handling.

### 0.2.1 Transport

The goods have to be carefully handled in order to prevent damage.

The end flange caps supplied are to be fitted to the valve as applicable.

### 0.2.2 Unpacking

Unpack the shipment, check to make sure that all contents are present and undamaged.

### 0.2.3 Storage

If the valve is not to be installed immediately following delivery, it must be properly stored.

Storage should be in a dry room at a temperature as constant as possible. Product should not be stacked on top of one another.

Storage over a longer period may necessitate individual moisture proof packing. This is dependent on the local conditions.

### 0.2.4 Disposal, Recycle or Return shipment

The personnel responsible for disposal of the product or associated components are to comply with federal, state and local requirements.

If the return shipment is required, contact manufacturer at the address listed within this manual for specific instructions.



The operator of valves used for aggressive or toxic media such as caustic chemicals must ensure that these are well flushed and cleaned before being handed to the maintenance personnel. This is particularly important when returning to the product manufacturer, disposing of or recycling the product or its component parts. MSDS are required for authorization to return valves to the manufacturer.

## 0.3 Bonnet Options

The sealed bonnet is equipped with a special “v-notch” vent plug which permits safe inspection for diaphragm rupture. Carefully loosen the v-notch vent plug 2-3 turns. Fluid seepage indicates a diaphragm failure has occurred. Replace diaphragm immediately. The non sealed bonnet has a weep hole that permits leakage of the process fluid if the diaphragm ruptures. If leakage is visible, replace diaphragm immediately. Failure to follow these instructions could result in serious personal injury or death, and property damage.

## 1.0 INSTALLATION

### CAUTION!

#### Weld End Valves

Weld end valves for schedule 10 and heavier pipe require bonnet and diaphragm removal prior to welding in line. See Section 3.4, steps 1-3, 6-10. 2.0mm and lighter pipe and tubing may be welded with automatic equipment without removing the diaphragm. Manual welding requires diaphragm removal for all pipe wall thickness.

1.1 Pure-Flo diaphragm valves may be installed in any orientation. To ensure optimum draining in horizontal

pipelines, the valve should be installed so that one of the drain marks on either valve end is precisely in the 12 o'clock position.

Note: According to good practice, horizontal pipework should be sloped toward the drain point to ensure optimum draining.

1.2 **CAUTION!** Prior to pressurization (with the valve open), tighten the bonnet nuts in a crisscross pattern in accordance with Table 1.

It is recommended that bonnet fasteners be retightened at ambient conditions after the system has cycled through operating pressure and temperature. If leakage occurs at the body-diaphragm seating area, immediately depressurize system and tighten bonnet nuts as noted above. If leakage continues, diaphragm replacement is required. See Section 3.4.

1.3 The travel stop (see Fig. 1) should be adjusted at time of installation. See Section 2.3.

## 2.0 OPERATION & ADJUSTMENT

### 2.1 General

The valve is closed with a clockwise rotation of the handwheel. See Table 2 for stroke length and number of turns information.

### 2.2 Sealed Bonnet (Fig. 2)



When the process fluid is a hazardous or corrosive material, extra precautions should be taken. The user should be prepared to control an external leak or spill of the process when using the v-notch vent plug (see description below). In addition, the bonnet internals and seals should be constructed of materials suitable for exposure to the process fluid or gas. If in doubt, contact ITT for evaluation.

The sealed bonnet is equipped with a special “v-notch” vent plug which permits safe inspection for diaphragm rupture. Carefully loosen the v-notch vent plug 2-3 turns. Fluid seepage indicates a diaphragm failure has occurred. Replace diaphragm immediately.

Failure to follow these instructions could result in serious personal injury or death, and property damage.

### 2.3 Travel Stop

The purpose of the travel stop is to prevent over closing of the valve, thus prolonging diaphragm life. The travel stop (see Fig. 1) should be adjusted at time of installation. The following procedure should be followed:

The first (and preferred) option is to install the valve in a test fixture (Figure 4). Supply air pressure equal to the system operating pressure to one side of the valve. Cap the other side of the valve and install a venting rubber or plastic tube. Hold the tube in a container of water. Air bubbles indicate leakage. Tighten the valve

until the leakage stops. Adjust the travel stop nut tight against the spacer.

If a test fixture is not available, the following procedure may be used.

#### For Elastomer Diaphragms Only:

1. Remove pressure from the line containing the valve.
2. Remove bonnet bolts and nuts. Remove the bonnet and unscrew the diaphragm from the compressor.
3. Replace the bonnet on the valve body (without a diaphragm).
4. Replace two bonnet bolts and nuts on opposite sides of the bonnet, hand tight.
5. Turn the handwheel until the compressor touches the weir. The valve will not close further.
6. Screw the travel stop nut down until it seats on the spacer. The travel stop is now adjusted.
7. Remove the bonnet from the valve body. Screw a diaphragm into the compressor hand tight. Then back it off until the bolt holes in the diaphragm and bonnet flange align.
8. Rotate the handwheel counterclockwise just enough to permit flange area of diaphragm to rest flat against flange area of bonnet.
9. Replace the bonnet, which now includes the diaphragm, on the valve body. The bonnet should be opened one-half to one turn of the handwheel. Tighten the bonnet nuts in accordance with Section 1.2.

If a test fixture is not available for valves with PTFE diaphragms, use the following procedure:

1. Loosen travel stop nut.
2. Turn handwheel clockwise until the initial resistance of the diaphragm seating is felt. From this point, turn the handwheel another 5/8 turn.
3. Turn the travel stop nut down until it bottoms on the spacer.

### 3.0 MAINTENANCE

**ALL MAINTENANCE PROCEDURES MUST BE PERFORMED BY QUALIFIED PERSONNEL. MAINTENANCE DONE BY PERSONNEL NOT QUALIFIED TO PERFORM IT COULD RESULT IN PERSONAL INJURY, DEATH OR PROPERTY DAMAGE.**



Remove all line pressure.

#### 3.1 Periodic inspection



When the process fluid is hazardous or corrosive, extra precautions should be taken. The user should employ appropriate safety devices and should be prepared to control a leak of the process fluid. Failure to follow these instructions could result in serious personal injury or death, and property damage.

Periodically inspect condition of external valve parts. Replace all parts showing excessive wear or corrosion. On sealed bonnet valves, back off the v-notch vent plug 2 or 3 turns. Fluid seeping from the plug indicates a diaphragm failure. Replace diaphragm immediately.

Contact manufacturer at the address listed within this manual in order to obtain replacement parts or for specific instructions.

3.2 If body-diaphragm seating area leaks, depressurize system and open valve slightly. Tighten bonnet nuts as described in Section 1.2. If leakage continues, diaphragm replacement is required.

3.3 If leakage is occurring around the handwheel, spindle, or through a bonnet weep hole, the diaphragm is ruptured and must be replaced.

#### 3.4 Diaphragm Replacement:

1. Remove pressure from line containing valve. Rotate handwheel clockwise to just close valve.
2. Remove bonnet nuts.
3. Lift off bonnet and unscrew diaphragm from compressor by turning counter-clockwise.
4. Periodically inspect valve compressor pin for excessive wear. Replace pin and/or compressor if excessive wear or axial pin movement. See Figure 1.
5. Replacement diaphragm should be identical size and grade as original diaphragm. See Figure 3 for location of size and grade marking.
6. Unscrew the diaphragm from the compressor by turning counterclockwise.
7. For PTFE assemblies only:
  - a. Install the new elastomer backing cushion over the tube nut.



- b. Invert the PTFE diaphragm by pressing the center of the diaphragm face with your thumbs while holding the edge of the diaphragm with your fingers.



- c. Engage the threads of the diaphragm into the tube nut by rotating clockwise.



- d. Continue rotating the PTFE diaphragm clockwise into the compressor while securing the backing cushion from rotating.

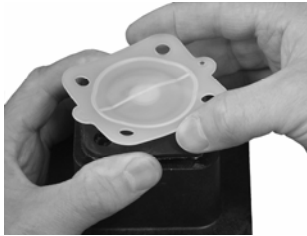

8. Rotate the diaphragm until hard stop or heavy resistance is achieved and additional force does not significantly rotate the diaphragm into the compressor.

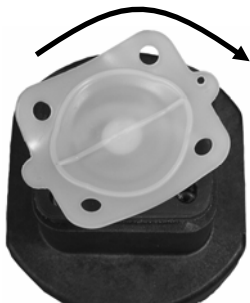

9. For PTFE assemblies only reinvert diaphragm.



10. Back off (no more than 1/2 turn) until the bolt holes in diaphragm and the bonnet flange align.



11. Rotate handwheel counterclockwise just enough to permit flange area of diaphragm to rest flat against flange area of bonnet.
12. Replace valve bonnet on body and tighten bonnet nuts hand tight.
13. Open bonnet one half to one turn of the handwheel. Tighten bonnet nuts evenly with a wrench (see Section 1.2).
14. If diaphragm leaks at body/bonnet joint after reaching temperature and pressure, depressurize system and retighten nuts in accordance with Section 1.2.

### 3.5 Lubrication

**CAUTION!** Standard lubricants are as outlined below. Special lubricants may be required for oxygen or other unique services. Contact ITT for evaluation of non-standard lubricants.

3.5.1 Bonnets are not equipped with grease fittings and must be disassembled to be lubricated. Under normal operation, lubrication is not necessary. If re-lubrication is necessary remove residual grease prior to re-lubrication.

3.5.2 Where valves are exposed to corrosive atmospheres or weather conditions, contacting surfaces of the handwheel and bonnet shell should be lubricated.

3.5.3 Standard lubricant is Chevron FM ALC EP.

Size	PAS Bonnet Bolt Torque in-lbs (N-m)	
	PTFE	Elastomer
.5" DN15	20 - 50 (2.3 - 5.7)	20 - 40 (2.3 - 4.5)
.75" DN20	40 - 70 (4.5 - 7.9)	20 - 50 (2.3 - 5.7)
1" DN25	45 - 80 (5.1 - 9.1)	25 - 70 (2.8 - 7.9)
1.25" & 1.5" DN32 & DN40	145 - 170 (16 - 19)	75 - 130 (8.5 - 14.7)
2" DN50	225 - 275 (25 - 31)	100 - 180 (11 - 20)
2.5" DN65	500 - 830 (57 - 94)	300 - 420 (34 - 48)
3" DN80	500 - 830 (57 - 94)	300 - 420 (34 - 48)
4" DN100	200 - 575 (23 - 65)	180 - 220 (20 - 25)

Size	Metal Bonnet Bolt Torque in-lbs (N-m)	
	PTFE	Elastomer
.5" DN15	25 - 80 (2.8 - 9.1)	20 - 40 (2.3 - 4.5)
.75" DN20	50 - 80 (5.7 - 9.1)	20 - 50 (2.3 - 5.7)
1" DN25	65 - 120 (7.4 - 13.6)	45 - 70 (5.1 - 7.9)
1.25" & 1.5" DN32 & DN40	200 - 225 (23 - 25)	75 - 130 (8.5 - 14.7)
2" DN50	225 - 300 (25 - 34)	100 - 180 (11 - 20)
2.5" DN65	750 - 1000 (85 - 113)	300 - 420 (34 - 48)
3" DN80	750 - 1000 (85 - 113)	300 - 420 (34 - 48)
4" DN100	540 - 600 (61 - 68)	190 - 230 (22 - 26)

**TABLE 1**

**Notes:**

1. Make multiple criss-cross passes to build up torque to final table values. Make additional criss-cross passes using table values to evenly tighten each bolt to within 5% of stated torque.
2. Values given are for lubricated fasteners.
3. Minimum values given will provide longer diaphragm cycle life for valves in non-autoclave and low thermal cycle conditions.
4. Maximum values given may be required for autoclave conditions and for high thermal cycle conditions.
5. Torques should be applied at near ambient conditions (< 100° F)

### 3.6 O-Ring Replacement (Fig. 2)

1. Remove bonnet nuts and lift off bonnet. Remove clear plastic cap and travel stop nut.
2. Loosen handwheel setscrew(s) and remove handwheel from bonnet.
3. Remove diaphragm/spindle/bushing assembly by withdrawing through bottom of bonnet.
4. Remove o-ring from groove in bushing outside diameter.
5. Unscrew diaphragm/spindle assembly from bushing.
6. Remove o-ring from groove in spindle outside diameter.
7. Lubricate thrust bearing or washer in accordance with Section 3.5. Install on shoulder of bushing.
8. Cover stem threads with masking tape to protect o-ring during installation. After o-ring installation, be sure to completely remove tape. Select correct size for o-rings 1 and 2 (figure 2). Lubricate new o-rings in accordance with Section 3.4 and insert into grooves in bushing and spindle.
9. Screw diaphragm/spindle assembly into bushing.
10. Install diaphragm/spindle/bushing assembly into bonnet.
11. Verify shim washer is installed. Install handwheel and tighten setscrew(s), ensuring end of setscrew(s) engages hole(s) in bushing. A thread locking compound is recommended. (except for plastic handwheels).
12. Select correct size for o-ring 3. Install. Screw cap onto bushing hand tight.

### 3.7 Change Diaphragm Type

To change from an elastomer diaphragm to PTFE, the compressor must be changed, and a tube nut must be installed.

1. Follow procedure 3.6, steps 1-3.
2. Drive out the spring pin which retains the compressor.
3. Install tube nut into hexagonal hole in new compressor. Then locate the new compressor on the spindle and drive in the spring pin.

To change from a PTFE diaphragm to elastomer, the compressor must be changed. The procedure is the same as above, except a tube nut is not required.

Size	Stem Travel (inches)	Stem Travel (mm)	Number of Turns
.5" DN15	0.25	6.4	2
.75" DN20	0.38	9.5	3
1" DN25	0.50	13	4
1.25" & 1.5" DN DN32 & DN40	0.81	21	4.88
2" DN50	1.12	29	6.75
2.5" DN65	1.61	41	8.12
3" DN80	1.61	41	8.12
4" DN100	2.12	54	10.62
6" DN150	3.12	79	10.62

**TABLE 2**  
Valve Travel and Number of Turns

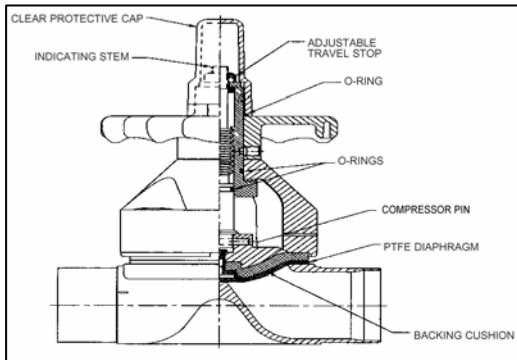

**Figure 1**

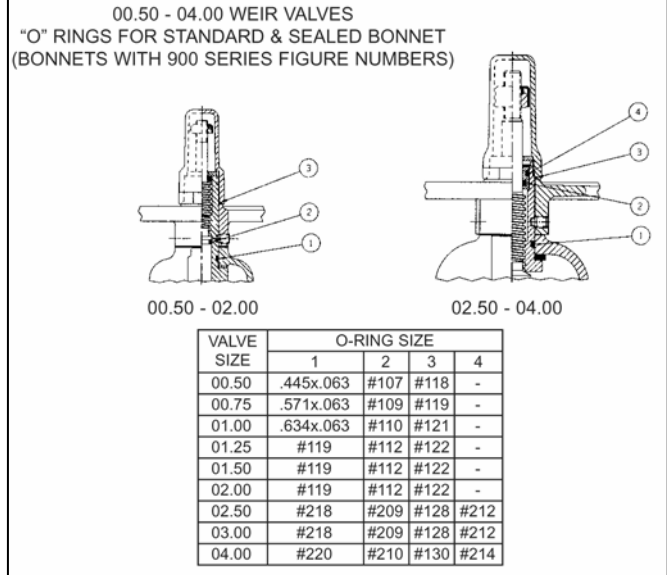

**Figure 2**

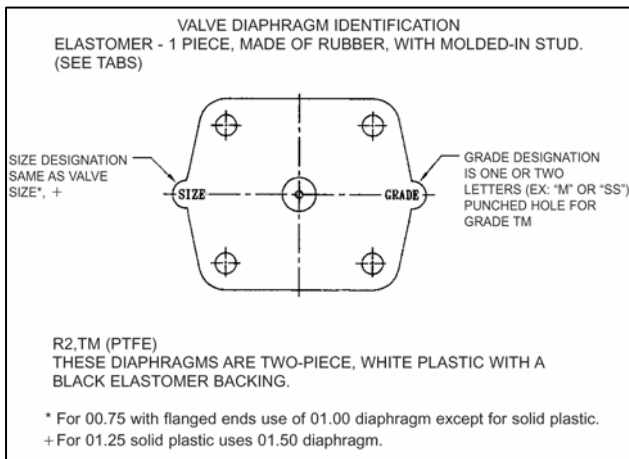

**Figure 3**

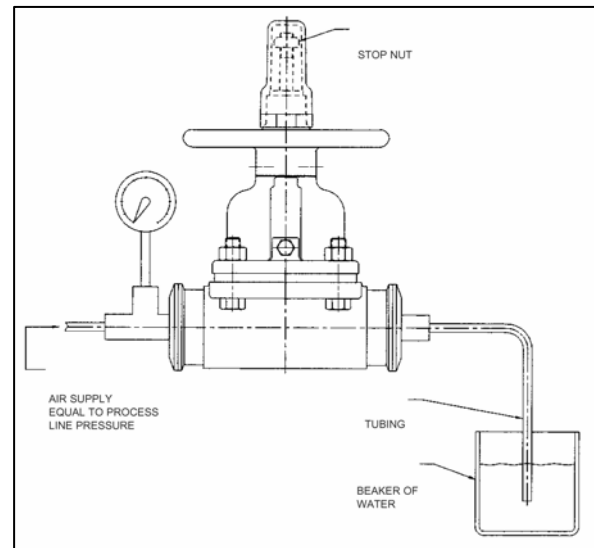

**Figure 4**

For more information, please contact:

**ITT Pure-Flo**

33 Centerville Road, P.O. Box 6164

Lancaster, PA 17603-2064 USA

Phone: (800) 366-1111

(717) 509-2200

Fax: (717) 509-2336

Website: [www.ittpureflo.com](http://www.ittpureflo.com)

E-mail: [pureflo.custserv@itt.com](mailto:pureflo.custserv@itt.com)

**OFFICE LOCATIONS**

**ITT Pure-Flo**

110-B West Cochran

Simi Valley, CA 93065USA

Phone: (805) 520-7200

Fax: (805) 520-7205

**ITT Pure-Flo**

Richards Street, Kirkham

Lancashire PR4 2HU United Kingdom

Phone: +44 1772-682696

Fax: +44 1772-686006



Indianapolis • Chicago • San Juan

[www.hollandapt.com](http://www.hollandapt.com)

800-800-8464