

spirax /sarco[®]

Stainless Steel Filter CSF26

The CSF26 is an in-line all 316 stainless steel filter suitable for use in steam, gas and liquid systems. The CSF26 is USDA approved, and conforms to the requirements of 3-A Accepted Practice Number 609-01 for the production of culinary steam. The CSF26 utilizes a fully cleanable sintered stainless steel element for reduced cost of ownership.

Model ↔	CSF26
Sizes	1/2", 3/4", 1", 1-1/2", 2", 2-1/2", 3"
Connections	NPT (1/2" - 2"), ANSI 150 (2-1/2" & 3")
Construction	Body: 316 Stainless Steel Element: 316 Stainless Steel
Element Rating	2.8 microns Absolute
Options	Tri-Clamp [®] compatible, flanged ANSI 150 (1/2"-2") and BSP connections, 4" & 6" sizes

Typical Applications

The CSF26 is ideally suited for culinary applications, where steam is being directly injected into food product, wash-down water, etc. Other applications include autoclaves, sterilizers and humidification systems often found in the healthcare and pharmaceutical industries.

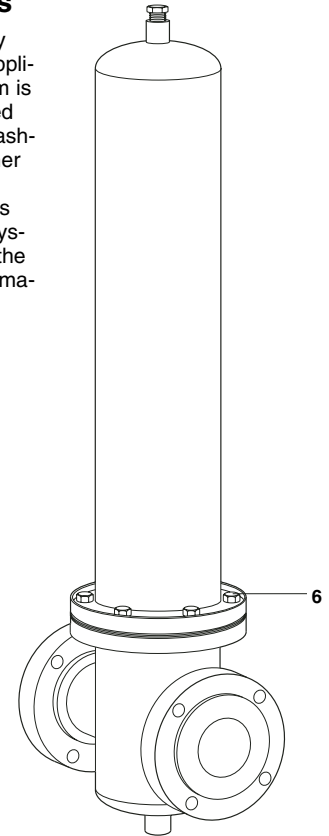

Limiting Operating Conditions

Max. Operating Pressure (PMO) 150 psig/(10.3 barg)

Max. Operating Temperature (TMO) 366°F/(186°C)

Pressure Shell Design Conditions

PMA 275 psig/0-100°F 19 barg/0-38°C
 Max. allowable pressure

TMA 750°F/0-95 psig 399°C/0-6.5 barg
 Max. allowable temp.

Element Design Conditions 15 psi/1 bar
 Max. element differential pressure

Construction Materials

No.	Part	Material
1	Filter Body	Stainless Steel
		1/2" & 3/4" SA-351 CF3M
		1" - 2-1/2" SA-351 CF8M
		3" SA-240 Gr. 316
2	Filter Bowl	Stainless Steel
		1/2" & 1" SA-240 Gr. 316L
		1-1/2" - 3" SA-240 Gr. 316
3	Plug	Stainless Steel 316
4	O-Ring	EPDM
5	Body Clamp (1/2"-2-1/2")	Stainless Steel 300 Series
6	Bolt (3" only)	Stainless Steel SA-193 Gr. B8
7*	Nut (3" only)	Stainless Steel 304
8	Element	Stainless Steel 316L Sintered Media
		End Caps
		SA-479 Gr. 316
9	O-Rings (2)	EPDM

* Not shown in drawing.

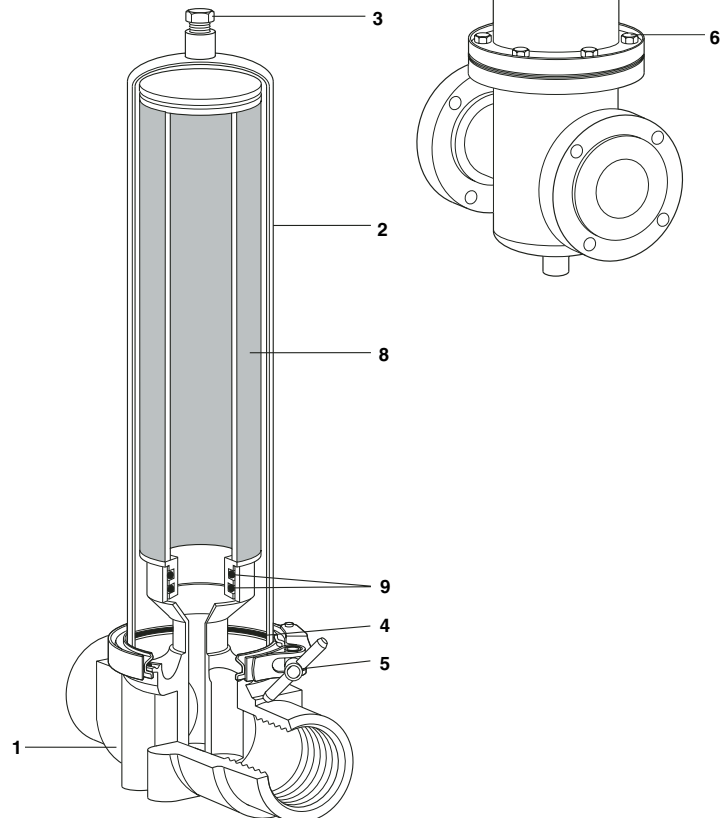

Stainless Steel Filter CSF26

Dimensions (nominal) in inches and millimeters						
Size	A	B	C	D	E	Weight
1/2"	8.0 203	4.3 110	0.6 14	2.5 64	7.0 178	3.6 lb 1.6 kg
3/4"	8.9 225	4.9 124	0.6 16	2.5 64	8.0 203	4.2 lb 1.9 kg
1"	9.6 245	4.9 124	1.3 32	4.0 102	7.0 178	5.9 lb 2.7 kg
1-1/2"	13.8 349	6.3 160	1.6 40	4.0 102	10.0 254	10.5 lb 4.8 kg
2"	22.3 565	6.7 170	1.9 48	4.0 102	18.0 457	14.0 lb 6.3 kg
2-1/2"	28.9 734	11.0 279	3.5 89	4.0 102	23.0 584	33.0 lb 15.0 kg
3"	44.0 1118	14.0 356	6.1 154	6.6 168	30.0 762	80.0 lb 36.4 kg

Vent and drain connection on all sizes - 1/4" NPT. Weight includes element.

Capacities – The following table lists CSF26 capacities, in lb/h of saturated steam, based on a pipeline velocity of 100 ft/s and an approximate differential pressure across the filter of 1 psi.

Steam Supply Pressure psig	Filter Size						
	1/2"	3/4"	1"	1-1/2"	2"	2-1/2"	3"
10	35	65	110	270	445	640	1,000
20	50	90	150	370	615	880	1,375
30	60	110	190	470	780	1,120	1,745
40	75	135	230	565	945	1,350	2,110
50	90	160	270	660	1,105	1,585	2,470
60	100	185	310	755	1,265	1,810	2,830
70	115	210	350	850	1,420	2,040	3,180
80	125	230	385	950	1,580	2,270	3,535
90	140	255	425	1,040	1,740	2,495	3,885
100	150	280	460	1,130	1,895	2,710	4,235
110	165	300	500	1,230	2,050	2,945	4,585
120	175	325	540	1,320	2,210	3,170	4,945
130	190	350	575	1,400	2,365	3,395	5,290
140	200	370	615	1,500	2,520	3,615	5,635
150	210	390	650	1,600	2,675	3,840	5,985

For liquid and gas applications, consult factory.

Higher capacities are available with 4" and 6" size filters. For further information, consult factory.

Steam Filter Efficiency

The 2.8 micron absolute rated filter element will remove 95% of all particles exceeding 2 microns.

Filter Stations

Also available from Spirax Sarco are a range of steam filter stations which conform to the requirements of the 3-A Accepted Practice Number 609-01. Each filter station includes a moisture separator with trap-set, strainer, CSF26 filter, together with the necessary auxiliary products required for efficient steam filtration. Further details are available upon request.

Sample Specification

Steam filter shall be all 316 stainless steel, with cleanable sintered stainless steel element. Filter element to utilize double O-Ring seal, and be capable of removing 95% of all particles 2 microns and above. Body and element seals to be an FDA approved material.

Installation & Maintenance

When used in steam service, it is recommended to remove the plastic drain plug and fit the CSF26 with a condensate drain trap and an air vent (Spirax Sarco MST 21). To prolong service life and ensure optimum filter efficiency, a strainer and separator should be installed upstream of the filter. This will ensure that entrained moisture and larger solid particles such as rust and pipescale are removed prior to filtration. It is recommended that the element be removed for cleaning when the differential pressure across the filter reaches 10 - 15 psi. Cleaning can be achieved either chemically or ultrasonically. **Complete installation and maintenance instructions, which include element cleaning procedures, accompany the product.**

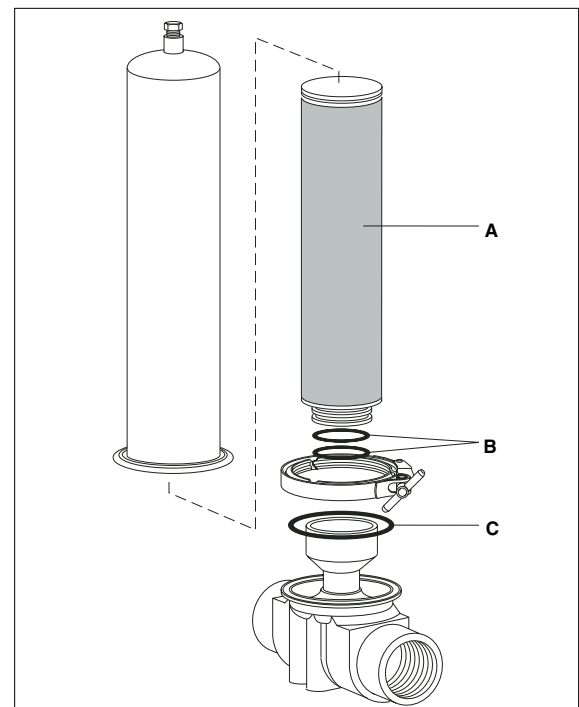
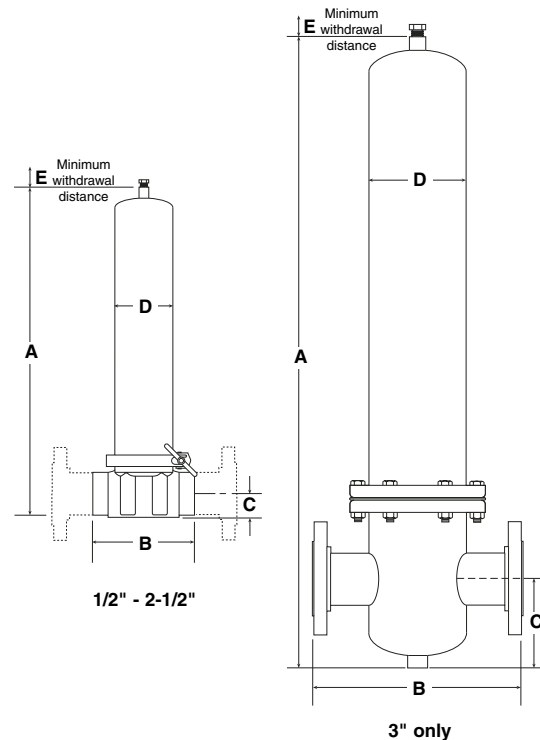

Spare Parts

Filter Element with O-Rings	A
Filter Element O-Rings(Pack of 2)	B
Body O-Rings(Pack of 2)	C

TI-7-005-US 11.03