



Thermowells

Holland[®]
APPLIED TECHNOLOGIES
 Indianapolis • Chicago • San Juan
www.hollandapt.com
 800-800-8464

Sanitary Clamp Type, also known as bi-metal wells, are designed for use with any 1/4" diameter probe having a 1/2" NPT threaded connector. This includes bi-metal thermometers, RTD's and temperature transmitters. Special thermowells for smaller diameter probes are also available for fractional size lines. Additional features include 316L grade material, with electropolished finish.

The Sanitary Projectile Type thermowell is designed to be welded into process and storage vessels and accept a variety of mechanical and electronic sensors. These sensor fittings are specially designed to provide metal-to-metal contact for fast response. They are provided with permanently etched "heat" numbers providing material and traceability. Material certificates are available at no extra charge.

SPECIFICATIONS

Sanitary Clamp Type

Material:

316 "L" stainless steel (certificates available)

Finish:

R_a Max= 8 microinches (.2 microns)

<u>Tri-Clamp Size</u> [®]	<u>Insertion</u>	<u>Model Number</u>
1-1/2 inches	3-1/16 inches	52500A0003
2 inch	3-9/16 inches	52501A0005
2-1/2 inch	3-9/16 inches	52501A0006
3 inches	3-13/16 inches	52502A0005
4 inches	3-13/16 inches	52502A0006

Sanitary Projectile Type

Material:

316 "L" stainless steel

Internal Thread:

1-1/4 inches x 18 UNEF

Finish:

R_a Max = 8 microinches (.2 microns) electropolished

Probe Type:

Accepts probe type 062-139

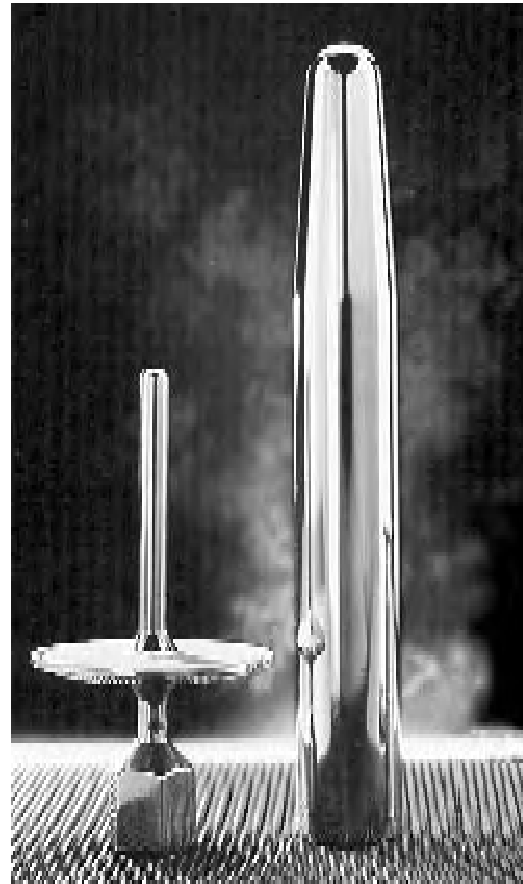

Thermowell Dimensions

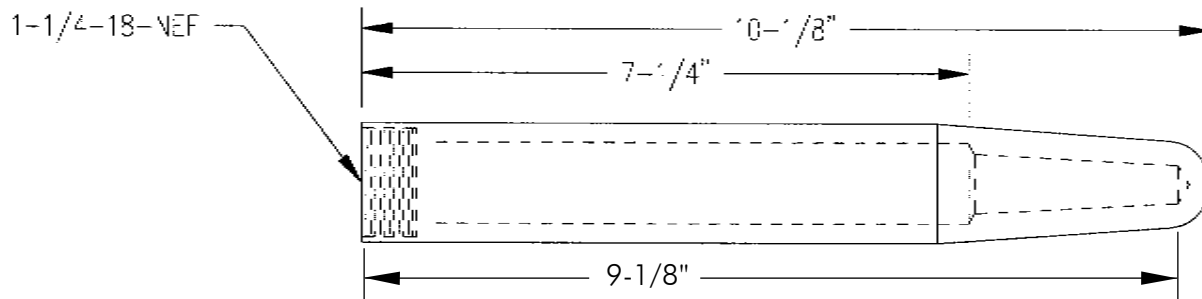

Pharmaceutical Wells: 1.5" - 4" Tri-Clamp
"A" Dim. (insertion length) varies with fitting

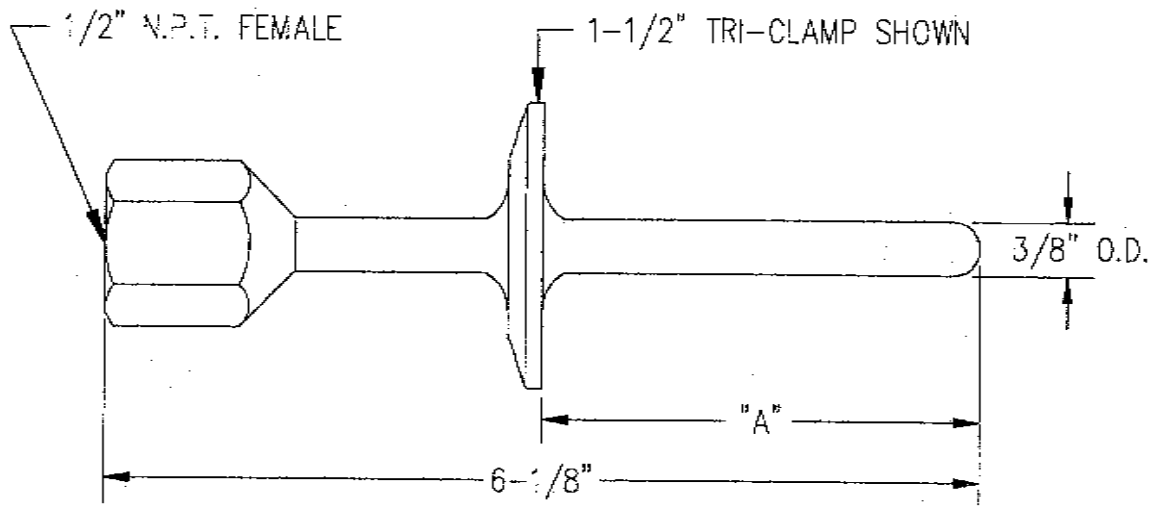

Tri-Clamp Size	Insertion
1-1/2 inches	3-1/16 inches
2 inch	3-9/16 inches
2-1/2 inch	3-9/16 inches
3 inches	3-13/16 inches
4 inches	3-13/16 inches

Form AIC3567 3/98
 Revised: November 2004
 Supersedes: December 2003