

## Stainless Steel High Capacity Thermostatic Steam Trap BT6HC

The BT6HC high capacity thermostatic steam trap is designed for steam use up to 87 psig saturated steam. This trap is manufactured from 316L stainless steel and has polished internal surfaces to 32 microinches Ra. Designed for clean and hygienic steam systems, the BT6HC will discharge condensate close to saturated steam temperature. When cold, its high capacity will allow CIP/SIP fluids to flow freely prior to normal steam operation.

<b>Model</b> ⇄	<b>BT6HC</b>
<b>PMO</b>	87 psig
<b>Sizes</b>	1", 1-1/2"
<b>Connections</b>	Tri-Clamp® compatible sanitary clamp ends
<b>Construction</b>	316L Stainless Steel body & internals

### TYPICAL APPLICATIONS

For SIP applications requiring high steam loads and/or high CIP discharge rates in process vessels, bioreactors and storage vessels.

\* A registered trademark of Tri-Clover Inc.

### LIMITING OPERATING CONDITIONS

**Max. Operating Pressure (PMO)** 87 psig (6 barg)

**Max. Operating Temperature** Saturated Steam Temperature

### PRESSURE SHELL DESIGN CONDITIONS

**PMA** 145 psig/0-338°F 10 barg/0-150°C  
 Max. allowable pressure 132 psig/350°F 9 barg/177°C

**TMA** 350°F/0-132 psig 177°C/0-9 barg  
 Max. allowable temperature

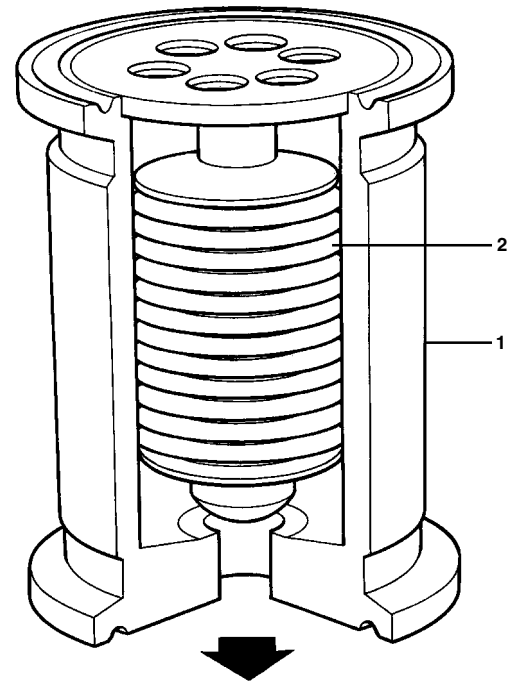

### CAPACITIES

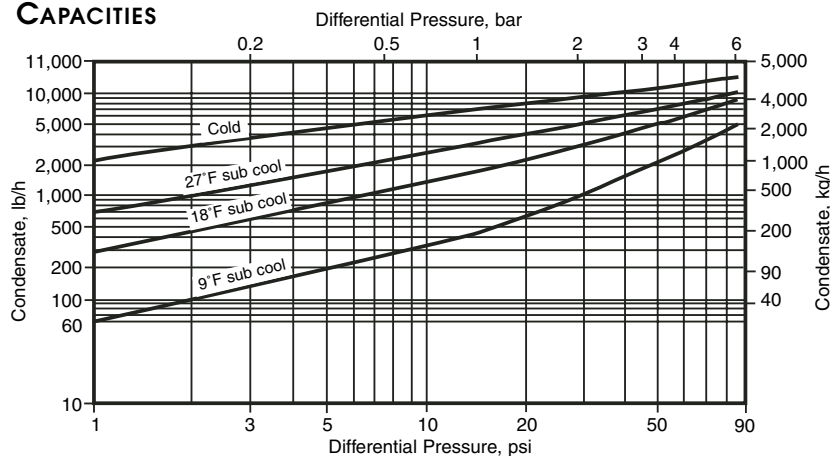

### CONSTRUCTION MATERIALS

No.	Part	Material
1	Body	Stainless Steel ASTM A276 Gr. 316L
2	Element	Stainless Steel ASTM A276 Gr. 316L

### MATERIAL CERTIFICATION

Actual mill test reports covering the BT6HC body material are available if specified at the time of ordering.

# Stainless Steel High Capacity Thermostatic Steam Trap BT6HC

## DIMENSIONS (NOMINAL) IN INCHES AND MILLIMETERS

Size	A	B	Weight
1", 1-1/2"	2.56 65	2.0 51	.90 lb .41 kg

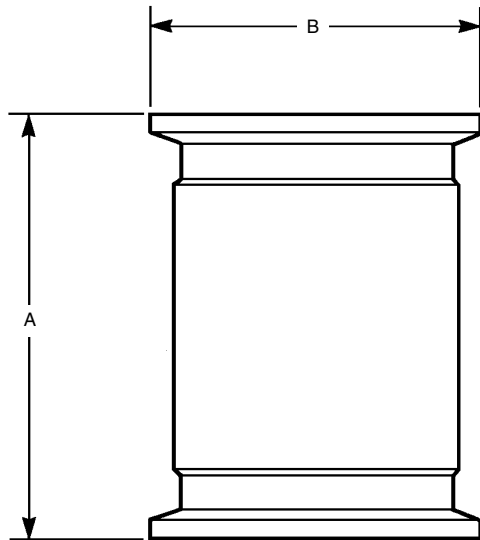

## SPARE PARTS

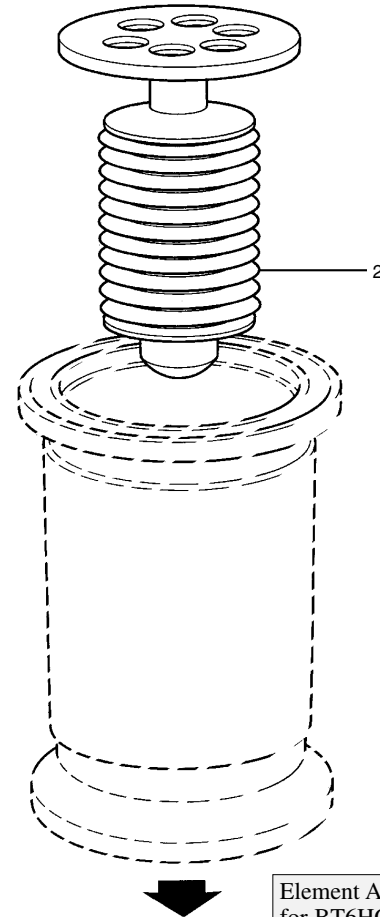

## ELEMENT OPERATION

During CIP operations the trap will be fully open to allow maximum flow of the cleaning fluid. On steam start up the trap will remain open until all air and noncondensibles are purged from the system. Under normal operation conditions the trap will typically begin to open at approximately 5°F below steam saturation temperature at the trap inlet. Some variation will exist depending on actual pressure and load conditions.

**Note:** The BT6HC must be allowed to cool to ambient temperature prior to CIP operation

## INSTALLATION

All packing to be removed from the trap, including the internal element support prior to installation. The trap is designed to be installed in vertical lines with the flow downwards so that it can be completely self draining. Full flow isolating valves (such as the Spirax Sarco Model 61 sanitary ball valve) should be installed to permit servicing. Check flow direction arrow for correct orientation. Tri-Clamp fittings and gaskets are supplied by the installer. Do not expose the element to superheat conditions as over expansion may result.

## MAINTENANCE

Before undertaking any maintenance on the trap it must be isolated from both supply line and return line and any residual pressure should be removed. The trap should then be allowed to cool.

### To replace element assembly

Undo the Tri-Clamp fittings and remove the trap from the line. Remove the element assembly and fit new assembly. Replace trap in the line together with the required gaskets and retighten the Tri-Clamp fittings to the manufacturer's specified torque.

## SAMPLE SPECIFICATION

Steam trap shall be self-adjusting balanced pressure type capable of operating close to saturated steam temperature. All wetted parts shall be manufactured from 316L grade stainless steel with body parts finished internally to 32 micro inches Ra, equivalent to a minimum of 180 grit. Trap shall be completely self-draining when installed in vertical pipeline.