



P R E S S U R E
T E M P E R A T U R E
L E V E L
I N S T R U M E N T A T I O N
F L O W
A N A L Y T I C A L

Holland[®]
APPLIED TECHNOLOGIES
Indianapolis • Chicago • San Juan
www.hollandapt.com
800-800-8464

"EM-Series" 90mm Sanitary Pressure Gauge

- *The industry's only externally adjustable span and offset*
- *Designed specifically for SIP and autoclave applications*
- *Lowest/most narrow profile of any sanitary gauge*

The best just got better! With our re-designed 90mm sanitary pressure gauge, Anderson Instrument has raised the bar relative to performance, reliability, and ease of use.

Customers in the Pharmaceutical and Biotech market will recognize at a glance that we've maintained all our unique features like all-welded construction, electro-polished wetted parts, and standard calibration certifications. They'll also appreciate the new, compact profile that fits virtually anywhere while still maximizing readability. But what really

sets this gauge apart is the new offset adjustment that comes as a standard feature on every Pharmaceutical series gauge. Rear-mounted and unobtrusive, we even provide a special tool for the optional span adjustment so it's tamper-proof.

Complete specifications and ordering information are available on the reverse. For more information contact our Customer Service Department at 1-800-833-0081, or visit our website at www.andinst.com.



Complete Product Ordering Matrix



RANGE

029	30" Hg/0/30 PSIG	055	-1/0/2 BAR
031	30" Hg/0/60 PSIG	057	0/2 BAR
032	30" Hg/0/100 PSIG	056	-1/0/4 BAR
033	30" Hg/0/160 PSIG	058	0/2.5 BAR
034	30" Hg/0/300 PSIG	060	0/6 BAR
066	0/30 PSIG	061	0/10 BAR
069	0/60 PSIG	064	0/16 BAR
071	0/100 PSIG	067	0/40 BAR
074	0/160 PSIG		
077	0/300 PSIG		
082	0/600 PSIG		

DUAL SCALE RANGES

241	-0.1/0/0.2 MPa/BAR
242	-0.1/0/0.4 MPa/BAR
367	-0.1/0/0.7 MPa/BAR
243	0/0.25 MPa/BAR
244	0/0.4 MPa/BAR
245	0/0.6 MPa/BAR
246	0/1 MPa/BAR
857	0/2 MPa/BAR
929	30" Hg/0/30 psig - -1/0/2 BAR
931	30" Hg/0/60 psig - -1/0/4 BAR
932	30" Hg/0/100 psig - -1/0/7 BAR
933	30" Hg/0/160 psig - -1/0/11 BAR
934	30" Hg/0/300 psig - -1/0/20 BAR
966	0/30 psig - 0/2 BAR
969	0/60 psig - 0/4 BAR
971	0/100 psig - 0/7 BAR
974	0/160 psig - 0/11 BAR
977	0/300 psig - 0/20 BAR
982	0/600 psig - 0/40 BAR

NAME ON DIAL

01 Anderson Instrument Co.

MATERIALS OF CONSTRUCTION

A	Standard
B	C22 diaphragm*
C	C22 All product contact surface**
L	Standard w/Custom markings
M	C22 Diaphragm w/Custom markings*
N	C22 All contact surface w/Custom markings**

CAPILLARY FILL

1	Mineral Oil (Standard)
5	Propylene Glycol (Neobee-20)

CALIBRATION ADJUSTMENT/STOP

1	w/Re-Zero (Standard)
2	w/Re-Zero & Re-Span
3	w/Re-Zero w/ max pointer stop
4	w/Re-Zero & Re-Span w/ max pointer stop

DAMPENING

0	Standard Dampening
1	Glycerine Filled Case (OF)
2	Mechanical Dampening (MD)
3	Vented Case/Standard Dampening
4	Vented Case/Mechanical Dampening

MOUNT

1	Bottom	5	Left	7	Top
4	Back	6	Right		

FITTING

004	1-1/2" Tri-Clamp®
005	2" Tri-Clamp®
016	1-1/2" Cherry "I" (male)
017	2" Cherry "I" (male)
027	1-1/2" G&H "H" Line (male)
028	2" G&H "H" Line (male)
123	AIC CPM Flush Mount
099	2" Varivent

* 1-1/2" TC & 2" TC, other fittings available consult factory

** Available 1-1/2" TC & 2" TC only

Specifications

Typical Performance

Over-Range Capability:	at least 25% over range
Calibrated Accuracy:	± .75% F.S. from 10-90% of range
Repeatability:	± .25% of full scale
Linearity:	±.25% of full scale
Hysteresis:	±.25% of full scale
Stability:	Within specified accuracy for 6 months under normal operating conditions.
Process Temperature Limits:	25° to 250°F (-3° to 121°C)
Ambient Temperature Limits:	40° to 120°F (4° to 49°C)
CIP Temperature Limit:	250°F (121°C) continuous
SIP Temperature Limit:	300°F (149°C) for one hour
Autoclave Temperature Limit:	300°F (149°C) for one hour (unfilled case only)
Temperature Effect:	Less than .16% per 10°F change in process or ambient temperature
Storage Temperature Limits:	-22°F to 195°F (-30°C to 91°C) -22°F to 250°F (-30°C to 121°C)*

* Vented Case

Construction/Finish

All Product Contact Surface (Diaphragm and fitting):	Welded 316L stainless steel, electropolished. Maximum R _a = 8 microinches (.2 microns).
Bourdon Tube/Socket Construction:	Bronze bourdon/brass socket with silver soldered connections.
Movement Mechanism:	Brass.
Case/Stem:	Welded 304 stainless steel (polished).
Dial:	Adhesive-backed printed Mylar in various scales, 90mm diameter min.
Lens/Dial Plate	Corrosion resistant polysulfone able to withstand 325°F
Bezel:	304 stainless steel, polished, compression formed to case (non-removable).
Viewing Angle:	100 degrees minimum.

Operational

Actuating Fill:	100% mineral oil. Meets FDA requirements (21CFR, 172.878 and 178.3620(a)) Neobee-20 optional.
Case Fill:	Optional, glycerine 100% USP Food Grade.
Mechanical Dampening:	Optional. Standard and case filled gauges dampened to 25% to 50%. Mechanical dampening dampens 50% to 80% of pressure variations.
Re-Zero Adjustment:	Tamper resistant adjustment, +/-5% of span. Non interactive with span. External adjustment integrally located on back of case.
Re-Span Adjustment:	Externally accessible with tool (AIC #452380000) through rear of case. Adjustment up to +/-5% of span.
Standards:	Designed and manufactured to sound engineering practices in accordance with Article 3.3 of the PED 97/23/EC. Designed and tested in accordance with ASME B40.100. NEMA 4X, IP-66 CSA B51-03 CRN# CSA0F9754.5C

Dimensions

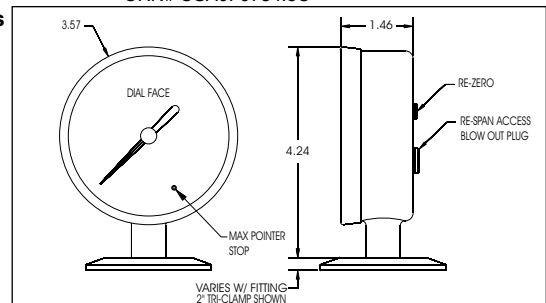

FORM AIC5017

© January 2004

Revised: May 2007

Supersedes: August 2005